

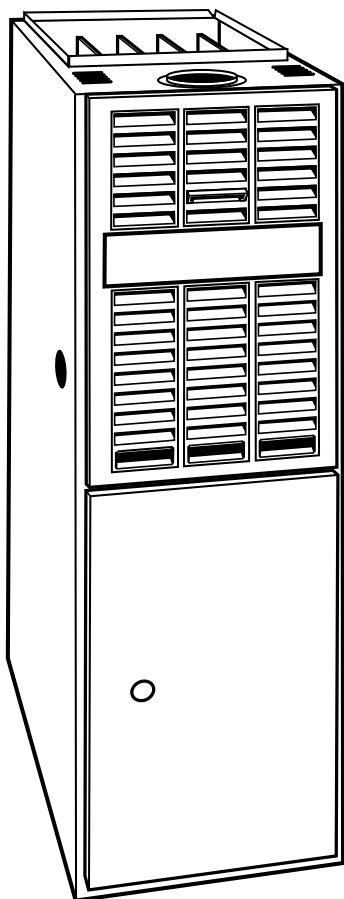

ENERGY-EFFICIENT INDUCED-COMBUSTION UPFLOW FURNACE

395CAV
Sizes 045 thru 155
Series G



With a unique approach to induced-combustion design, a 40-in. tall cabinet, 4-pass heat exchanger, an inshot burner system, and its safety features, this furnace is without peer. The model 395CAV Deluxe Induced-Combustion Upflow Furnace achieves one of the highest Annual Fuel Utilization Efficiency (AFUE) ratings available in a noncondensing, induced-combustion furnace. Its ease and economy of installation, ease of serviceability, economical initial cost, and short payback time put it in a class well ahead of the competition. The model 395CAV Gas Furnace has the kind of overall performance needed in today's homes. All models are GAMA efficiency rating certified and certified for use in California Air Quality Management Districts.

FEATURES

EFFICIENCY—The 395CAV Deluxe Induced-Combustion Gas Furnace provides the efficiency customers want with 80.0 percent AFUE.

HOT SURFACE IGNITION—This field proven ignition system will save energy and improve reliability.

ALUMINIZED HEAT EXCHANGER—The patented 4-pass heat exchanger is made of aluminized steel and backed by a 20-year Limited Warranty.

INTELLIGENT CONTROL BOARD—The 395CAV Furnace has an intelligent control board with an LED status indicator light to ensure top furnace performance. This control board also has a self-test feature that enables the servicing technician to verify operation of the board itself, the inducer, the hot surface ignitor, both high- and low-speed blower operation, and the humidifier. The board also features a 3-amp fuse that protects the transformer and board. We guarantee the reliability of the control board with a 3-year Limited Warranty.

40-IN. HEIGHT—The 395CAV Deluxe Induced-Combustion Furnace with a 40-in. cabinet height simplifies installation in alcoves, attics, basements (ideal for short basement), closets, and utility rooms, especially with a high-efficiency cooling coil.

PREPAINTED CABINET—The 395CAV uses prepainted sheet metal for the cabinet. This is the same high-quality finish found on refrigerators and other appliances today. We ensure its durability by using a galvanized steel substrate to provide superior rust protection.

PATENTED BLOCKED VENT SAFEGUARD—Our induced-combustion furnace has a patented blocked vent safeguard. The safeguard will stop furnace operation if the vent system becomes blocked or is not operating properly. An exclusive with the 395CAV Furnace.

EASY INSTALLATION—The model 395CAV has many features that make installation easier: left or right gas and electrical connections, Molex blower speed selector, matching coil sizes, accessory low-voltage connections, and many more.

QUIET OPERATION—A soft mount inducer assembly and slow opening gas valve improves sound level.

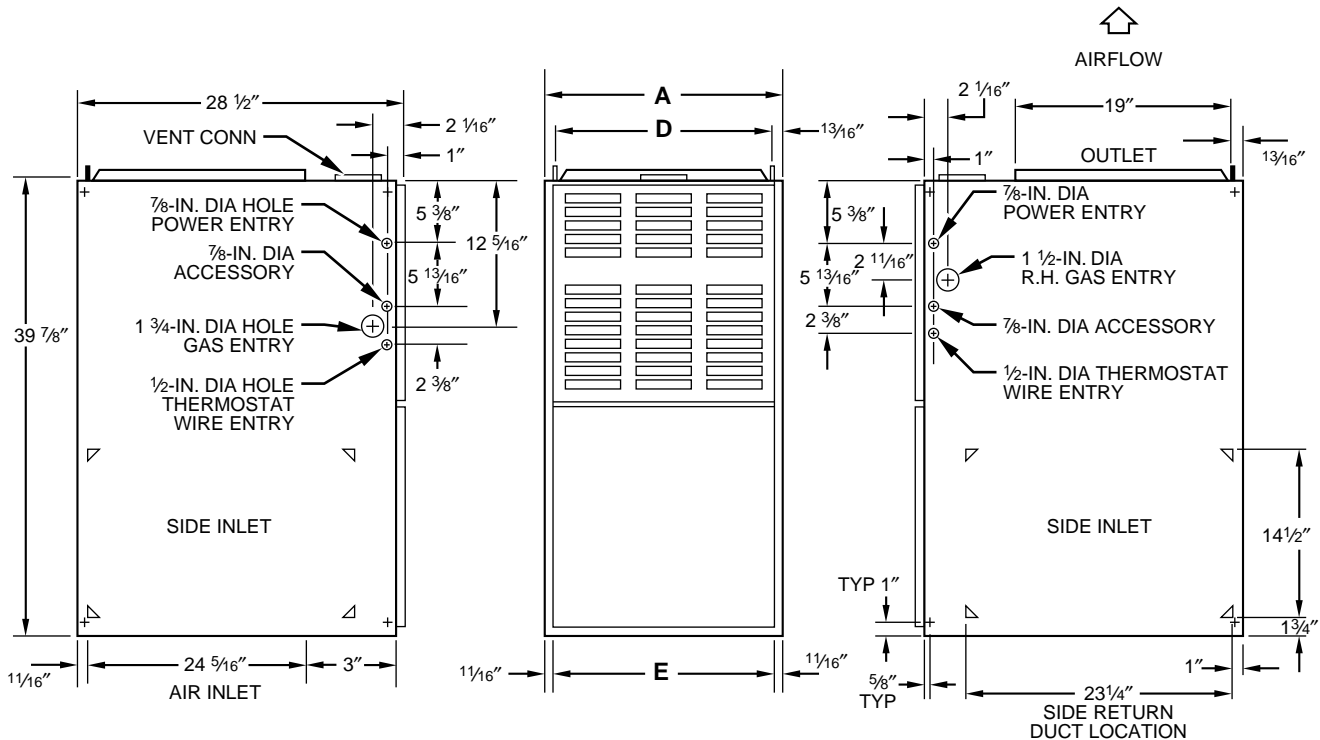

- NOTES:**
- Two additional 7/8-in. dia holes are located in the top plate.
 - Minimum return-air openings at furnace, based on metal duct. If flex duct is used, see flex duct manufacturer's recommendations for equivalent diameters.
 - Minimum return-air opening at furnace:
 - For 800 CFM—16-in. round or 14 1/2 x 12-in. rectangle.
 - For 1200 CFM—20-in. round or 14 1/2 x 19 1/2-in. rectangle.
 - For 1600 CFM—22-in. round or 14 1/2 x 23 1/4-in. rectangle.
 - For airflow requirements above 1800 CFM, see Air Delivery table in Product Data literature for specific use of single side inlets. The use of both side inlets, a combination of 1 side and the bottom, or the bottom only will ensure adequate return air openings for airflow requirements above 1800 CFM.

A98520

DIMENSIONS (In.)

UNIT SIZE	A	D	E	VENT CONN* (Dia)	SHIPPING WEIGHT (Lb)
024045	14-3/16	12-9/16	11-11/16	4	122
036045	14-3/16	12-9/16	11-11/16	4	124
024070	14-3/16	12-9/16	11-11/16	4	132
036070	14-3/16	12-9/16	11-11/16	4	134
042091	17-1/2	15-7/8	16	4	150
048091	21	19-3/8	18-1/2	4	154
036111	17-1/2	15-7/8	16	4	160
048111	21	19-3/8	18-1/2	4	166
060111	24-1/2	22-7/8	22	4	184
048135	21	19-3/8	18-1/2	5†	178
060135	24-1/2	22-7/8	22	5†	194
060155	24-1/2	22-7/8	22	5†	204

* Refer to the furnace Installation Instructions for proper venting procedures.
 † Oval collar

OPTIONAL SIDE FILTER RACK

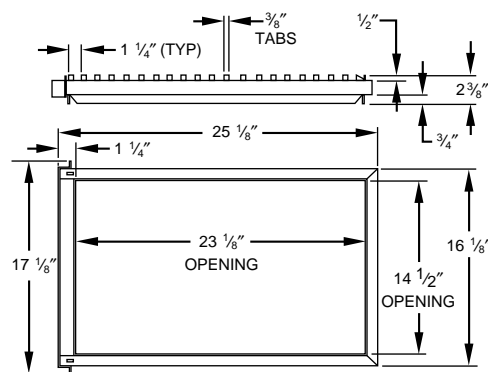

A80199



MEETS DOE RESIDENTIAL CONSERVATION SERVICES PROGRAM STANDARDS.

Before purchasing this appliance, read important energy cost and efficiency information available from your retailer.

MINIMUM INCHES CLEARANCE TO COMBUSTIBLE CONSTRUCTION

This forced air furnace is equipped for use with natural gas at altitudes 0 - 10,000 ft (0-3,050m).
 An accessory kit, supplied by the manufacturer, shall be used to convert to propane gas use or may be required for some natural gas applications.
 This furnace is for indoor installation in building constructed on site.
 This furnace may be installed on combustible flooring in alcove or closet at minimum clearance from combustible material.
 This furnace may be used with a Type B-1 Vent and may be vented in common with other gas-fired appliances.

- # For furnaces wider than 14.25 inches (362mm) may be 0 inches.
- ## For single wall vent type 6 inches.
For Type B-1 vent type 3 inches.

This furnace is approved for UPFLOW installations only.

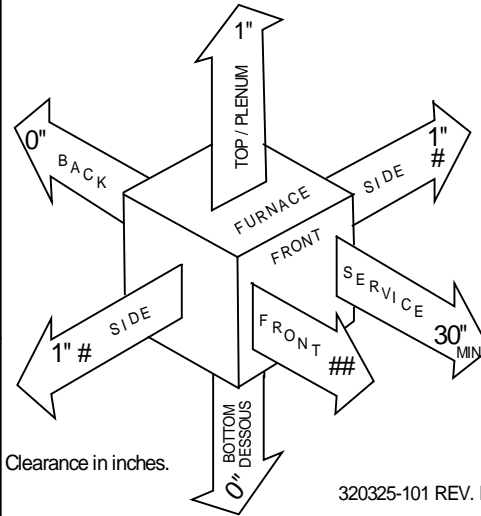

Clearance in inches.

320325-101 REV. H

Vent Clearance to combustibles:
 For Single Wall vents 6 inches (6 po).
 For Type B-1 vent type 1 inch (1 po).

A98122E

CONTROLS—THERMOSTATS AND ZONING

THERMOSTAT—NON-PROGRAMMABLE	Auto Changeover, °F/°C, 1-Stage Heat/1-Stage Cool — TSTATBBNAC01-B Auto Changeover, °F/°C, 2-Stage Heat/1-Stage Cool — TSTATBBNHP01-B Auto Changeover, °F/°C, 2-Stage Heat/2-Stage Cool — TSTATBBN2S01-B in AC Mode, 3-Stage Heat in AC Mode/2-Stage Cool in HP Mode Air Conditioner, 1-Stage Heat/1-Stage Cool, Manual Changeover, °F/°C — TSTATBBBAC01 Heat Pump, 2-Stage Heat/1-Stage Cool, Manual Changeover, °F/°C — TSTATBBBHP01*
THERMOSTAT—PROGRAMMABLE	Auto Changeover, 7-Day Programmable, °F/°C, 1-Stage Heat/1-Stage Cool — TSTATBBPAC01-B Auto Changeover, 7-Day Programmable, °F/°C, 2-Stage Heat/1-Stage Cool — TSTATBBPAC01-B Auto Changeover, 7-Day Programmable, °F/°C, 2-Stage Heat/2-Stage Cool — TSTATBBP2S01-B in AC Mode, 3-Stage Heat/2-Stage Cool in HP Mode Dual Fuel Thermostat, Includes Outdoor Air Temperature Sensor — TSTATBBPDF01-B* Thermostat Control — Non-Programmable/Programmable Thermostat — TSTATBBPRH01-B* with Humidity Control (For use in Dual Fuel, AC, HP, and 2S applications. Includes Outdoor Air Temperature Sensor.)
ZONING—2-ZONE	ZONEBB2KIT01, ZONEKIT2ZBDP
ZONING—4-ZONE	ZONEBB4KIT01
ZONING—8-ZONE	ZONEBB8KIT01

* Do not use in zoning heat pump applications.

SPECIFICATIONS

UNIT SIZE	024045	036045	024070	036070	042091	048091		
RATINGS AND PERFORMANCE								
Input Btuh*	44,000	44,000	66,000	66,000	88,000	88,000		
Output Capacity (Btuh)†	Nonweatherized ICS		35,000	35,000	53,000	53,000	71,000	71,000
AFUE‡	Nonweatherized ICS		80.0	80.0	80.0	80.0	80.0	80.0
Certified Temperature Rise Range °F			25—55	15—45	40—70	30—60	40—70	30—60
Certified External Static Pressure	Heat/Cool		0.10/0.50	0.10/0.50	0.12/0.50	0.12/0.50	0.15/0.50	0.15/0.50
Airflow CFM‡	Heating		855	980	830	1140	1170	1445
	Cooling		880	1250	880	1195	1360	1740
ELECTRICAL								
Unit Volts—Hertz—Phase	115—60—1							
Operating Voltage Range	Min—Max		104—127					
Maximum Unit Amps	6.0	8.3	5.9	8.7	9.0	10.4		
Maximum Wire Length (Measured 1 Way in Ft)	47	34	47	32	31	27		
Minimum Wire Size	14							
Maximum Fuse or Ckt Bkr Size (Amps)**	15							
Transformer (24v)	40va							
External Control	Heating		12va					
Power Available	Cooling		35va					
Air Conditioning Blower Relay	Standard							
CONTROLS								
Limit Control	SPST							
Heating Blower Control	Solid-State Time Operation							
Burners (Monoport)	2	2	3	3	4	4		
Gas Connection Size	1/2-in. NPT							
GAS CONTROLS								
Gas Valve (Redundant)	White Rodgers							
	Min Inlet Pressure (In. wc)		4.5 (Natural Gas)					
	Max Inlet Pressure (In. wc)		13.6 (Natural Gas)					
Ignition Device	Hot Surface							
BLOWER DATA								
Direct-Drive Motor HP (PSC)	1/5	1/3	1/5	1/3	1/3	1/2		
Motor Full Load Amps	2.9	5.8	2.9	5.8	5.8	7.9		
RPM (Nominal)—Speeds	1075—3	1075—4	1075—3	1075—4	1075—4	1075—4		
Blower Wheel Diameter x Width (In.)	10 x 6	10 x 6	10 x 6	10 x 6	10 x 7	10 x 8		
Filter Size (In.)—Permanent Washable (Supplied)	(1) 16 x 25 x 1					(1) 20 x 25 x 1		
FACTORY-AUTHORIZED DEALER-INSTALLED ACCESSORIES								
Twinning Kit	N/A					KGATW0401HSI		
Gas Conversion Kit—Natural-to-Propane	KGANP2001ALL							
Gas Conversion Kit—Propane-to-Natural	KGAPN1601ALL							
Side Filter Rack Accepts 1 Filter (In.)	KGAFR0201ALL (Filter Size 16 x 25 x 1)							
Air Cleaner	Model AIRA or 902B							
Humidifier	Model HUM							
Ventilator	Model VA3B, VB5B, VC5B, or VL3A							

* Gas input ratings are certified for elevations to 2000 ft. For elevations above 2000 ft, reduce ratings 4 percent for each 1000 ft above sea level. Refer to National Fuel Gas Code Table F4 or furnace Installation Instructions. In Canada, derate the unit 10 percent for elevations 2000 ft to 4500 ft above sea level.

† Capacity and AFUE in accordance with U.S. government DOE test procedures.

‡ Airflow shown is for bottom only return-air supply. For air delivery above 1800 CFM, see Air Delivery table for other options. A filter is required for each return-air supply.

** Time-delay type is recommended.

ICS—Isolated Combustion System

N/A—Not Applicable

SPECIFICATIONS

UNIT SIZE	036111	048111	060111	048135	060135	060155		
RATINGS AND PERFORMANCE								
Input Btuh*	110,000	110,000	110,000	132,000	132,000	154,000		
Capacity (Btuh)†	Nonweatherized ICS		89,000	89,000	89,000	107,000	107,000	124,000
AFUE†	Nonweatherized ICS		80.0	80.0	80.0	80.0	80.0	
Certified Temperature Rise Range °F			55—85	45—75	25—55	50—80	40—70	50—80
Certified External Static Pressure	Heat/Cool		0.20/0.50	0.20/0.50	0.20/0.50	0.20/0.50	0.20/0.50	0.20/0.50
Airflow CFM‡	Heating		1175	1415	1750	1645	1775	1770
	Cooling		1205	1575	2225	1620	2025	2055
ELECTRICAL								
Unit Volts—Hertz—Phase	115—60—1							
Operating Voltage Range Min—Max	104—127							
Maximum Unit Amps	8.0	10.1	14.4	10.1	13.3	14.0		
Maximum Wire Length (Measured 1 Way in Ft)	35	28	31	28	33	31		
Minimum Wire Size	14	14	12	14	12	12		
Maximum Fuse or Ckt Bkr Size (Amps)**	15	15	20	15	20	20		
Transformer (24v)	40va							
External Control	Heating		12va					
Power Available	Cooling		35va					
Air Conditioning Blower Relay	Standard							
CONTROLS								
Limit Control	SPST							
Heating Blower Control	Solid-State Time Operation							
Burners (Monoport)	5	5	5	6	6	7		
Gas Connection Size	1/2-in. NPT							
GAS CONTROLS								
Gas Valve (Redundant)	White Rodgers							
	Min Inlet Pressure (In. wc)		4.5 (Natural Gas)					
	Max Inlet Pressure (In. wc)		13.6 (Natural Gas)					
Ignition Device	Hot Surface							
BLOWER DATA								
Direct-Drive Motor HP (PSC)	1/3	1/2	3/4	1/2	3/4	3/4		
Motor Full Load Amps	5.8	7.9	11.1	7.9	11.1	11.1		
RPM (Nominal)—Speeds	1075—4	1075—4	1075—4	1075—4	1075—4	1075—4		
Blower Wheel Diameter x Width (In.)	10 x 7	10 x 8	11 x 10	10 x 8	11 x 10	11 x 10		
Filter Size (In.)—Permanent Washable	(1) 16x25x1	(1) 20x25x1	(1) 24x29x1	(1) 20x25x1	(1) 24 x 29 x 1			
FACTORY-AUTHORIZED DEALER-INSTALLED ACCESSORIES								
Twinning Kit	N/A	KGATW0401HSI						
Gas Conversion Kit—(Natural-to-Propane)	KGANP2001ALL							
Gas Conversion Kit—(Propane-to-Natural)	KGAPN1601ALL							
Side Filter Rack Accepts 1 Filter (In.)	KGAFR0201ALL (Filter Size 16 x 25 x 1)							
Air Cleaner	Model AIRA or 902B							
Humidifier	Model HUM							
Ventilator	Model VA3B, VB5B, VC5B, or VL3A							

* Gas input ratings are certified for elevations to 2000 ft. For elevations above 2000 ft, reduce ratings 4 percent for each 1000 ft above sea level. Refer to National Fuel Gas Code Table F4 or furnace Installation Instructions. In Canada, derate the unit 10 percent for elevations 2000 ft to 4500 ft above sea level.

† Capacity and AFUE in accordance with U.S. government DOE test procedures.

‡ Airflow shown is for bottom only return-air supply. For air delivery above 1800 CFM, see Air Delivery table for other options. A filter is required for each return-air supply.

** Time-delay type is recommended.

ICS—Isolated Combustion System

N/A—Not Applicable

AIR DELIVERY—CFM (With Filters)*

UNIT SIZE	RETURN-AIR SUPPLY	SPEED	EXTERNAL STATIC PRESSURE (IN. WC)							
			0.1	0.2	0.3	0.4	0.5	0.6	0.7	0.8
024045	Bottom or 1 Side	High	1030	1005	970	925	880	815	745	615
		Med-High	855	830	800	765	720	670	595	485
		Med-Low	755	725	695	650	605	555	475	400
036045	Bottom or 1 Side	High	1490	1430	1385	1325	1250	1175	1085	975
		Med-High	1335	1305	1270	1230	1160	1090	1005	915
		Med-Low	1140	1130	1105	1075	1030	975	900	830
		Low	980	975	965	915	875	840	785	715
024070	Bottom or 1 Side	High	1040	1010	975	935	880	810	735	640
		Med-High	855	830	800	765	715	660	600	490
		Med-Low	745	715	690	650	605	550	475	385
036070	Bottom or 1 Side	High	1430	1380	1325	1265	1195	1125	1045	945
		Med-High	1310	1275	1235	1190	1135	1065	990	900
		Med-Low	1140	1130	1100	1065	1000	965	910	815
		Low	990	965	960	935	905	855	800	710
042091	Bottom or 1 Side	High	1570	1535	1480	1415	1360	1280	1185	1070
		Med-High	1370	1355	1330	1290	1240	1170	1080	955
		Med-Low	1170	1165	1150	1115	1085	1035	970	880
		Low	1010	1005	990	965	950	905	845	745
048091	Bottom or 1 Side	High	2010	1950	1875	1810	1740	1660	1550	1455
		Med-High	1675	1660	1625	1600	1545	1490	1395	1295
		Med-Low	1445	1430	1415	1400	1370	1325	1265	1170
		Low	1260	1260	1260	1250	1210	1180	1115	1030
036111	Bottom or 1 Side	High	1470	1415	1340	1270	1205	1115	985	845
		Med-High	1340	1305	1245	1185	1130	1045	915	780
		Med-Low	1185	1175	1140	1075	1030	950	835	705
		Low	1015	1010	980	955	910	840	725	600
048111	Bottom or 1 Side	High	1880	1815	1745	1690	1575	1500	1400	1265
		Med-High	1660	1615	1570	1505	1435	1355	1260	1170
		Med-Low	1455	1410	1375	1350	1290	1235	1145	985
		Low	1265	1265	1240	1210	1180	1110	995	855
060111	Bottom Only	High	—	2465	2385	2305	2225	2125	2020	1910
		Med-High	2125	2120	2075	2040	1985	1900	1825	1715
		Med-Low	1745	1750	1740	1720	1685	1635	1565	1500
		Low	1545	1545	1545	1520	1495	1450	1390	1330
	Both Sides or 1 Side & Bottom	High	2475	2465	2425	2365	2305	2230	2145	2015
		Med-High	2100	2080	2075	2055	2015	1940	1865	1765
		Med-Low	2415	2340	2250	2170	2070	2000	1890	1780
1 Side Only	Med-High	2080	2050	2010	1955	1885	1805	1745	1645	
048135	Bottom or 1 Side	High	1900	1845	1780	1705	1620	1530	1445	1320
		Med-High	1695	1645	1580	1520	1460	1385	1280	1155
		Med-Low	1460	1415	1375	1340	1290	1205	1110	—
		Low	1275	1260	1245	1230	1180	1135	—	—
060135	Bottom Only	High	—	2260	2185	2085	2025	1935	1835	1730
		Med-High	2110	2070	2015	1960	1885	1810	1715	1620
		Med-Low	1790	1775	1755	1720	1670	1610	1535	1455
		Low	1495	1500	1515	1485	1450	1400	1345	1270
	Both Sides or 1 Side & Bottom	High	2425	2360	2275	2195	2095	2010	1890	1775
		Med-High	2055	2035	1995	1945	1880	1810	1735	1640
		Med-Low	2245	2175	2070	1980	1900	1805	1695	1575
1 Side Only	Med-High	2050	1985	1925	1850	1765	1690	1585	1480	
060155	Bottom Only	High	—	2300	2235	2155	2055	1980	1870	1775
		Med-High	—	2050	2005	1945	1880	1805	1720	1640
		Med-Low	1790	1770	1740	1710	1635	1580	1520	1440
		Low	1520	1525	1505	1485	1450	1410	1350	1290
	Both Sides or 1 Side & Bottom	High	2405	2385	2310	2220	2140	2045	1945	1825
		Med-High	2090	2090	2040	1990	1925	1850	1765	1660
		Med-Low	2325	2260	2175	2085	2000	1900	1805	1705
1 Side Only	Med-High	2085	2045	1985	1920	1855	1765	1680	1570	

* A filter is required for each return-air supply.
 — Indicates unstable operating conditions.

SERVICE TRAINING

Packaged Service Training programs are an excellent way to increase your knowledge of the equipment discussed in this manual, including:

- Unit Familiarization
- Maintenance
- Installation Overview
- Operating Sequence

A large selection of product, theory, and skills programs is available, using popular video-based formats and materials. All include video and/or slides, plus companion book.

Classroom Service Training plus "hands-on" the products in our labs can mean increased confidence that really pays dividends in faster troubleshooting, fewer callbacks. Course descriptions and schedules are in our catalog.

CALL FOR FREE CATALOG 1-800-962-9212

Packaged Service Training

Classroom Service Training

A94328



SPECIFICATIONS SUBJECT TO CHANGE WITHOUT NOTICE

UNIT MUST BE INSTALLED IN ACCORDANCE
WITH INSTALLATION INSTRUCTIONS

Cancels: PDS 395CAV.40.6